



Design of Purified Water and Water For Injection Systems

Hugh Hodkinson
Engineers Ireland
Chemical & Process Division





Introduction

- My Background
- What's this lecture about?
- What should you get out of it?
 - Learn basic design rules for PUW & WFI
 - Understand where they came from
 - Know enough to query a design

What are PUW and WFI?



- Compendial Waters as classified by national and international organisations such as:
 - United States Pharmacopoeia (USP)
 - European Pharmacopoeia (Ph. Eur)
 - Japanese Pharmacopoeia (JP)

What are PUW and WFI used for?



- Product contact operations
- Typical PUW uses:
 - Bulk API or BPC Preparation
 - Non parenteral dosage forms
 - Laboratory activities
 - Cleaning of the above and initial rinses for the below
- Typical WFI uses:
 - Sterile Bulk API or BPC Preparation
 - Parenteral dosage forms
 - Final cleaning rinses for the above two applications

Purified Water



Parameter	Unit	USP	Ph. Eur. (Bulk)
TOC	ppb C	500	500
Conductivity	$\mu\text{S}/\text{cm}$ @ 20 °C	-	≤ 4.3
Conductivity	$\mu\text{S}/\text{cm}$ @ 25 °C	≤ 1.3	-
Nitrate (NO ₃)	ppm	-	≤ 0.2
Heavy Metals	ppm as Pb	-	≤ 0.1
Aerobic Bacteria	CFU/ ml	≤ 100	≤ 100

Water For Injection



Parameter	Unit	USP	Ph. Eur. (Bulk)
TOC	ppb C	≤ 500	≤ 500
Conductivity	$\mu\text{S}/\text{cm}$ @ 20 °C	-	≤ 1.1
Conductivity	$\mu\text{S}/\text{cm}$ @ 25 °C	≤ 1.3	-
Nitrate (NO ₃)	ppm	-	≤ 0.2
Aerobic Bacteria	CFU/ 100 ml	≤ 10	≤ 10
Bacterial Endotoxins	EU/ ml	≤ 0.25	-
Bacterial Endotoxins	I.U./ml	-	≤ 0.25

Why do we monitor these parameters?



- Conductivity: Ionic Contaminants
- TOC: Food for microbes
- Nitrates: Negative health impacts
- Heavy Metals: Toxic to humans and animals
- Aerobic Bacteria: Unwanted organisms
- Endotoxins: Dangerous in parenterals

History of Compendial Water



- Introductions to USP Prior to Nov. 1996:

- Sulfate 1840
- Calcium 1840
- Carbon Dioxide 1850
- Chloride 1890
- Ammonia 1890
- Oxidizable substances 1890
- Heavy Metals 1900
- Coliforms 1947
- Total Solids 1947
- pH 1970
- Bacterial endotoxins 1983

Why do we care about temperature?



Conductivity ($\mu\text{S}/\text{cm}$) vs. Temperature ($^{\circ}\text{C}$)

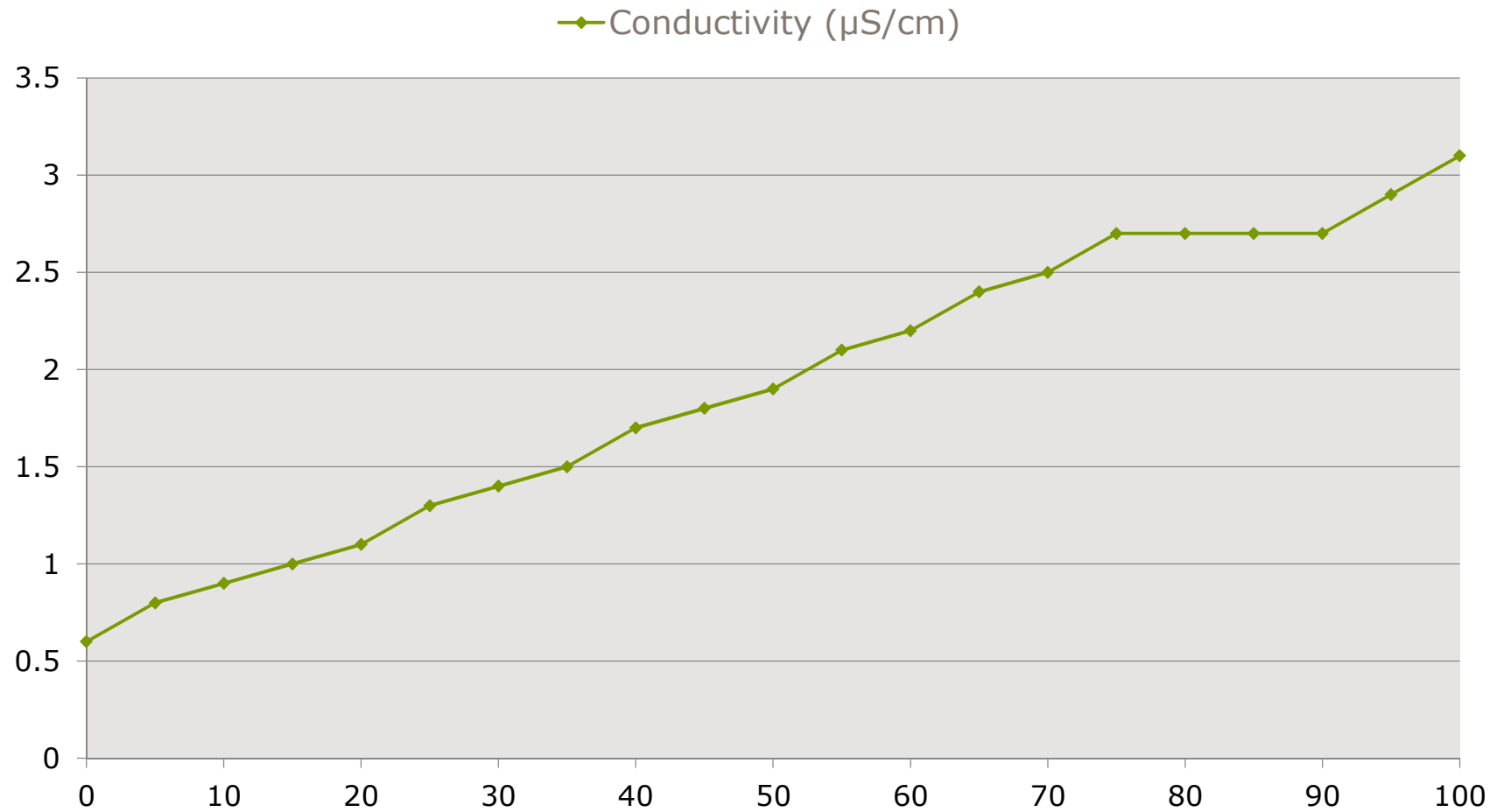

PUW Generation



How is PUW made?



By use of some or all of the following:

- Particulate Filter
- Activated Carbon
- Organic Scavengers
- Softeners
- Degassing Membrane
- Ion Exchange Columns/ Continuous Electro De-Ionisation
- Reverse Osmosis
- UV Lamp

WFI Generation



How is WFI made?



- In Europe, WFI can only be produced by distillation
- USP allows for WFI production by RO or by distillation
- JP allows for WFI production by RO, distillation or Ultra-Filtration
- Two main still designs: Vapour Compression and Multi-Effect

Multi-Effect Still Schematic

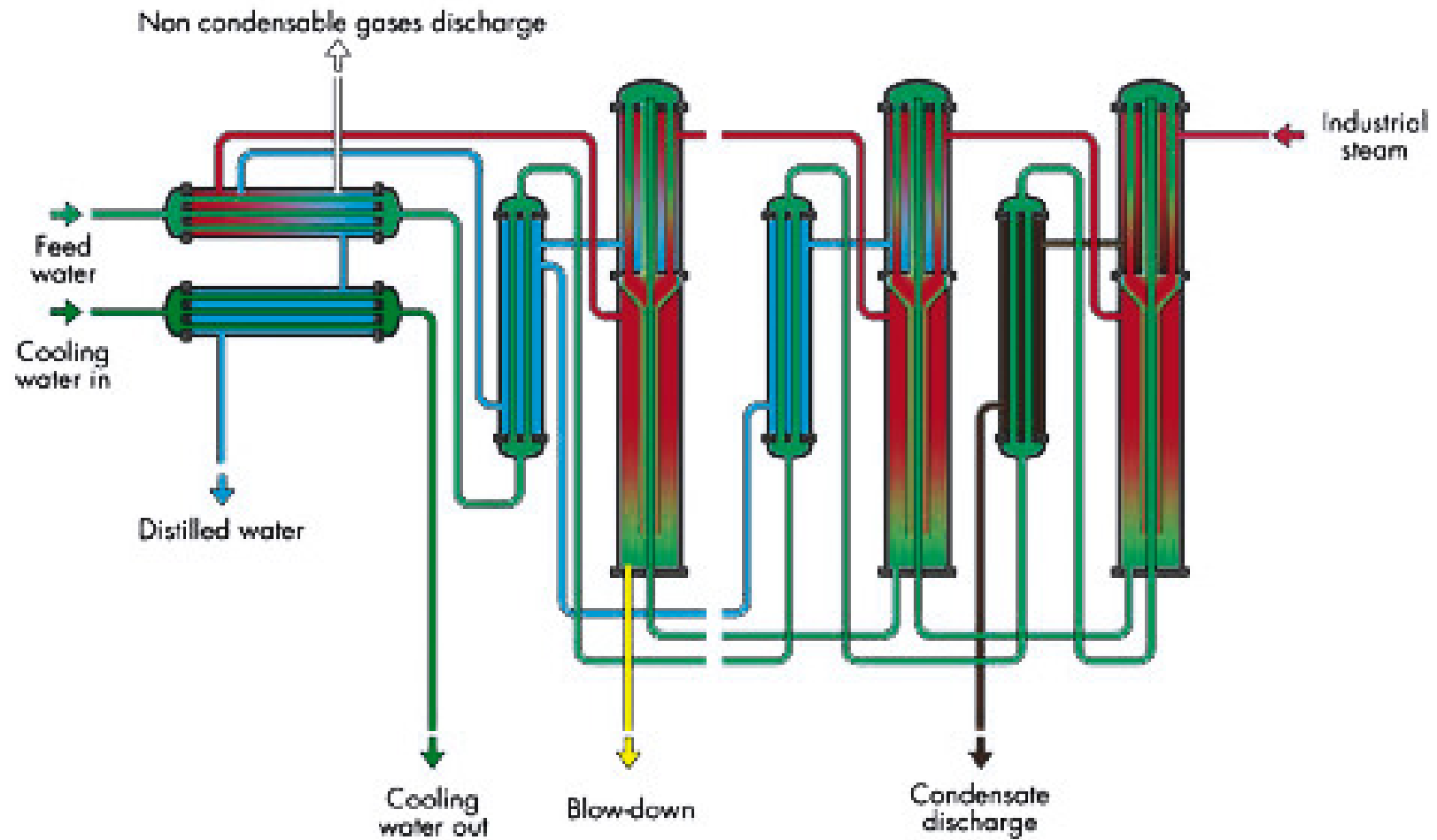

Vapour Compression Still Schematic

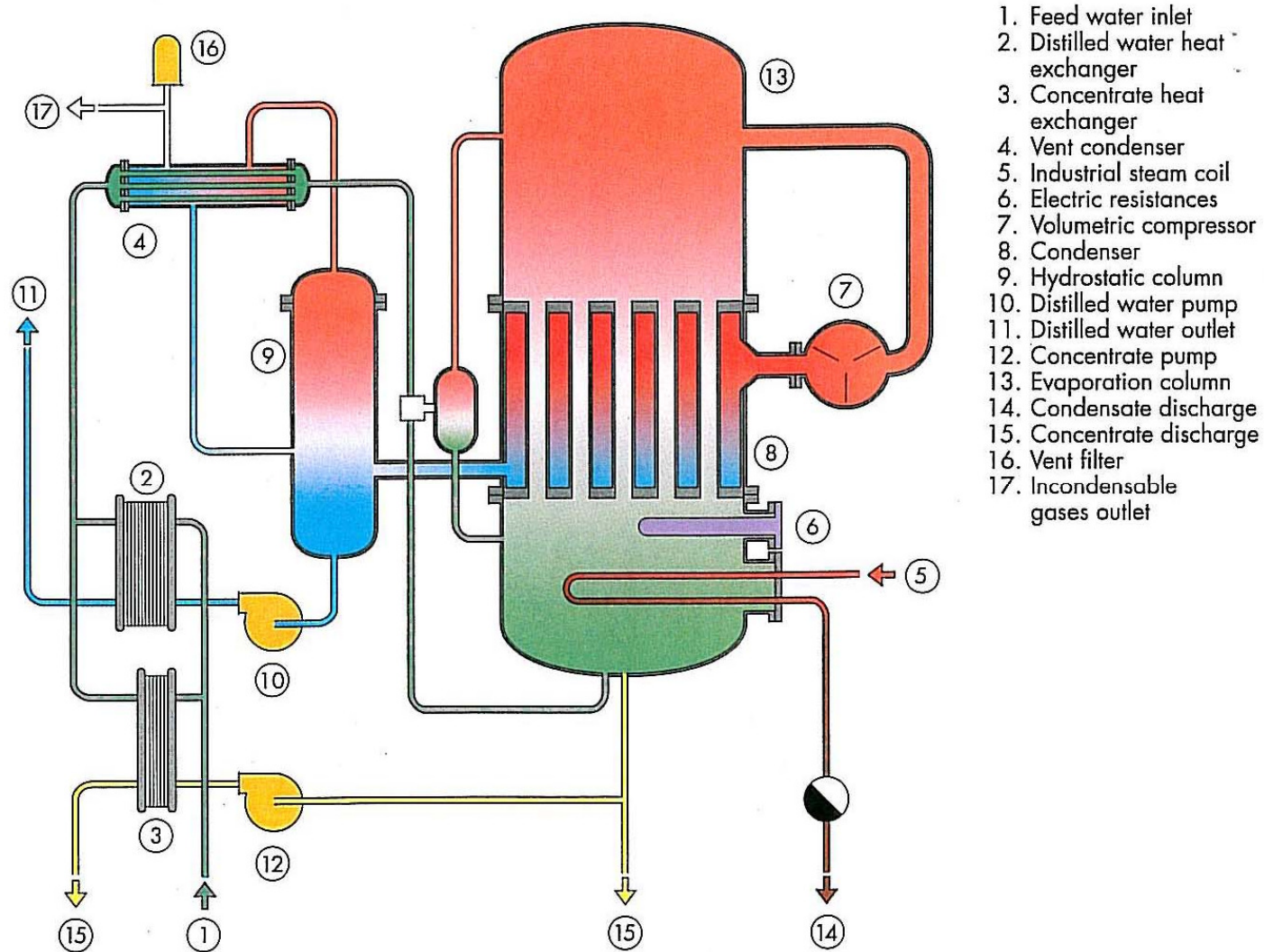

1. Feed water inlet
2. Distilled water heat exchanger
3. Concentrate heat exchanger
4. Vent condenser
5. Industrial steam coil
6. Electric resistances
7. Volumetric compressor
8. Condenser
9. Hydrostatic column
10. Distilled water pump
11. Distilled water outlet
12. Concentrate pump
13. Evaporation column
14. Condensate discharge
15. Concentrate discharge
16. Vent filter
17. Incondensable gases outlet

What is WFI made from?



- Its feedwater does **NOT** have to be PUW

Characteristic	Requirement
pH at 20 °C	6.5 – 8.5
Conductivity at 20 °C	< 10 µS/cm
Dissolved Solids	< 5 mg/l
Chlorides	< 50 ppb
Free Chlorine	< 50 ppb
Ammonia	< 50 ppb
Total Hardness	< 2 ppm
Silica as SiO ₂	< 1 ppm
Endotoxins	< 250 EU/ml

PUW/ WFI Storage and Distribution



- Ensure that it stays as PUW/ WFI
- Minimise microbial growth
 - Keep it moving
 - Heat, chilling or ozonation
 - Regular sanitisation
 - Polished surfaces: Ra < 0.5 µm is common
- Prevent any contamination from entering
 - Sealed system with 0.2 µm vent filters for breathing
 - Block and bleed assemblies at user points
 - Double sheet shell and tube/ double plate heat exchangers
 - Use materials which won't degrade water quality, such as 316 or 316L stainless steel, PTFE, EPDM, etc.

Hot PUW/ WFI Storage and Distribution

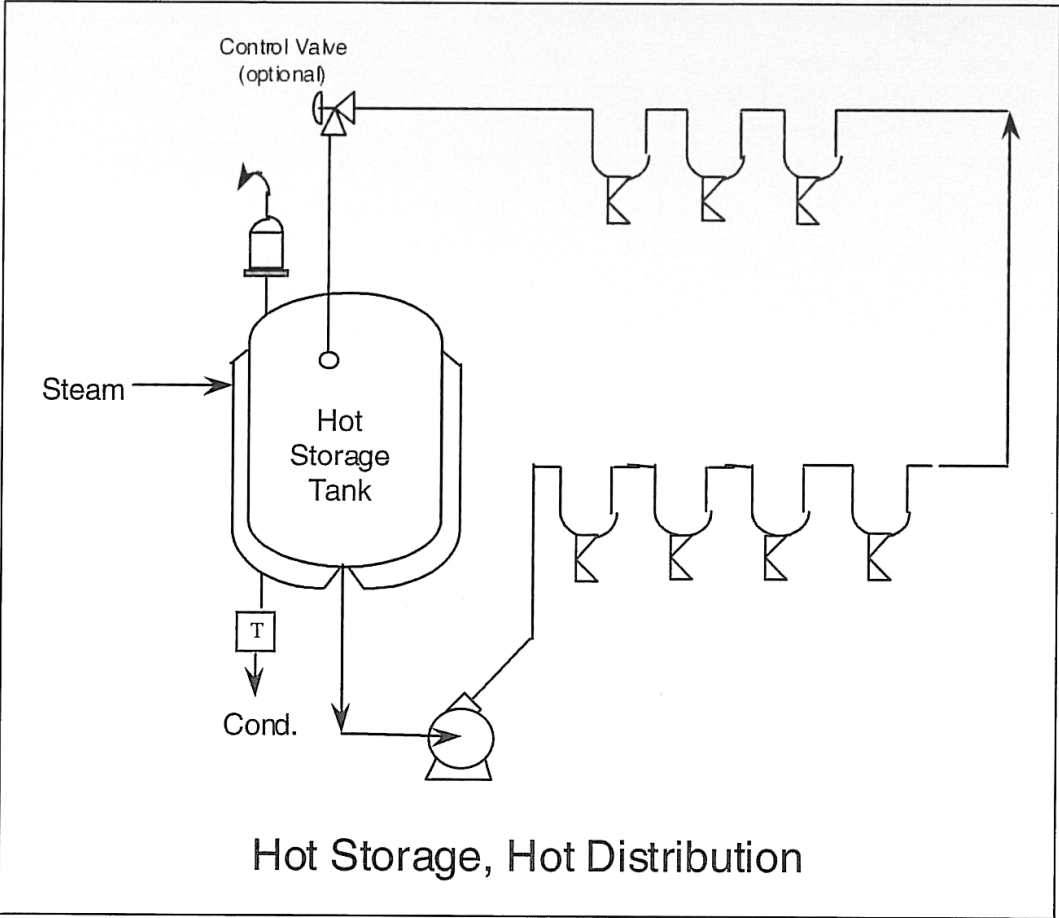

Hot PUW/ WFI Storage and Distribution with Cooled Sub-Loop

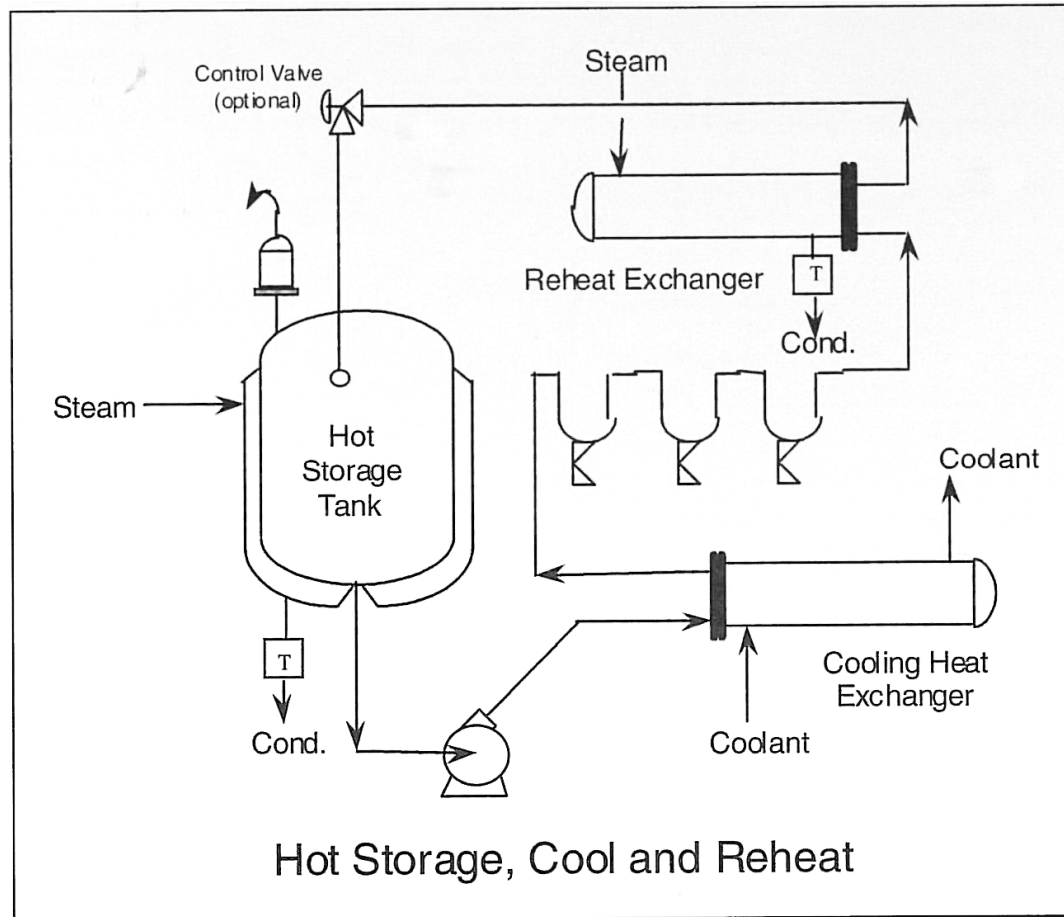

Ozonated PUW Storage and Distribution

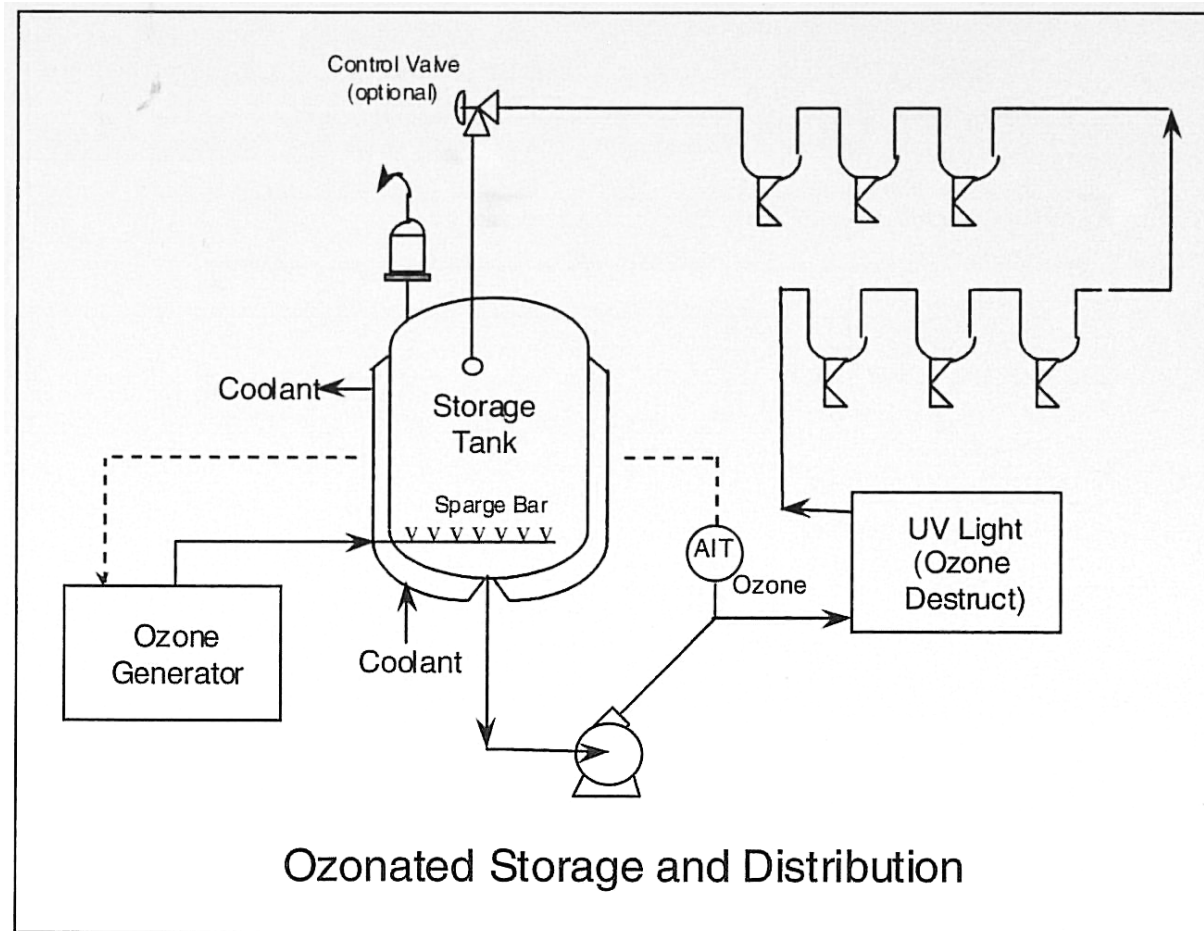

PUW/ WFI Storage and Distribution: Three Sub-Loops

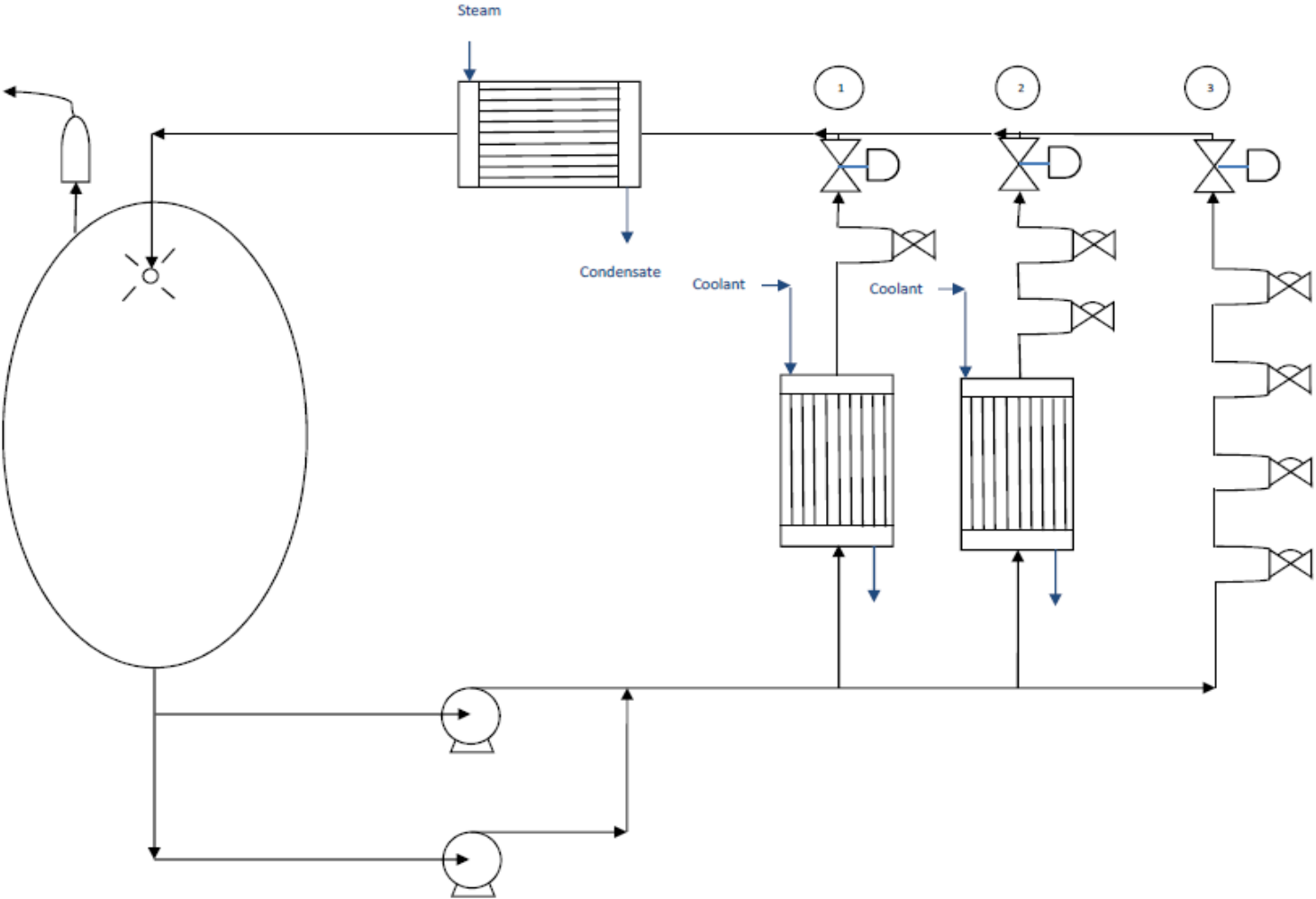

Economiser Heat Exchanger

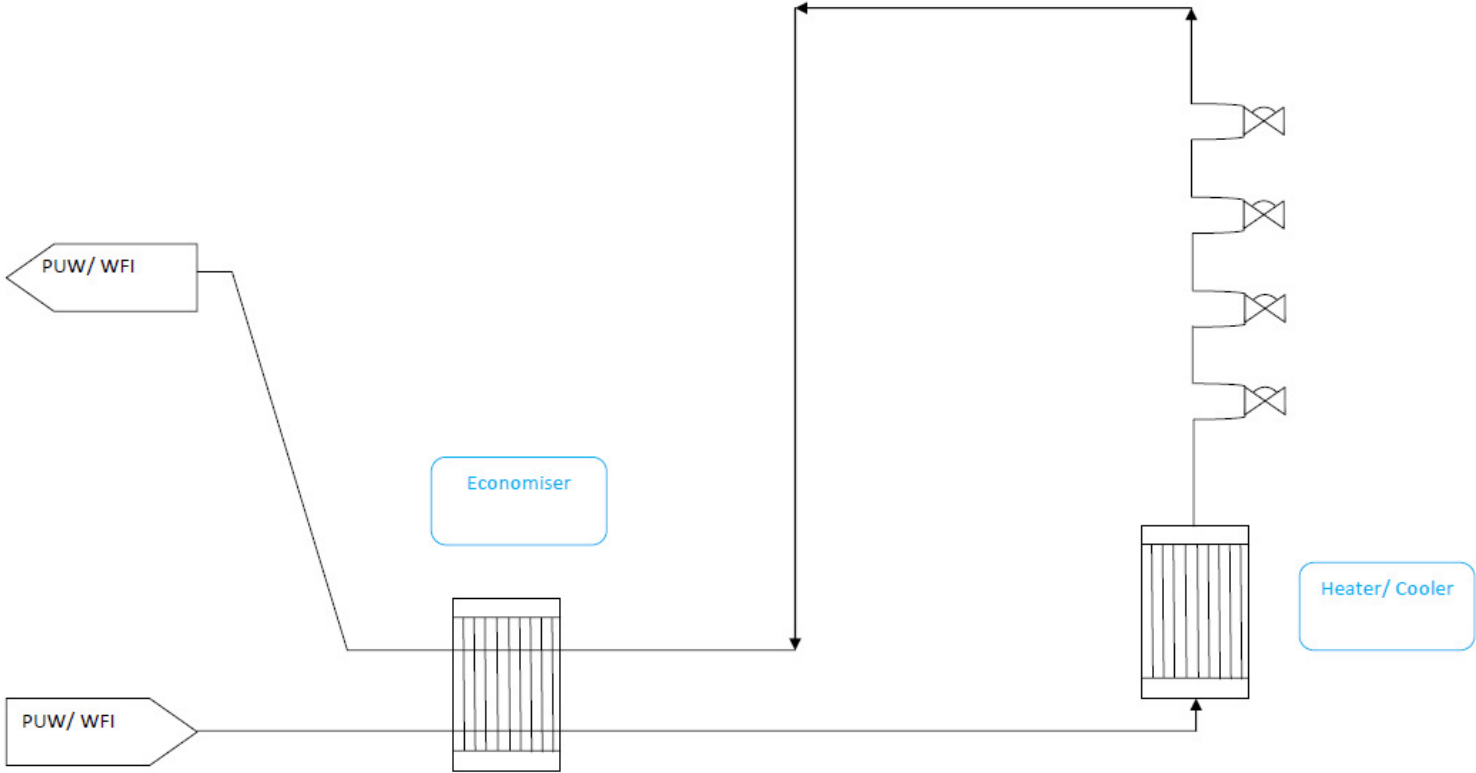

Sub-Loop Flush to Drain

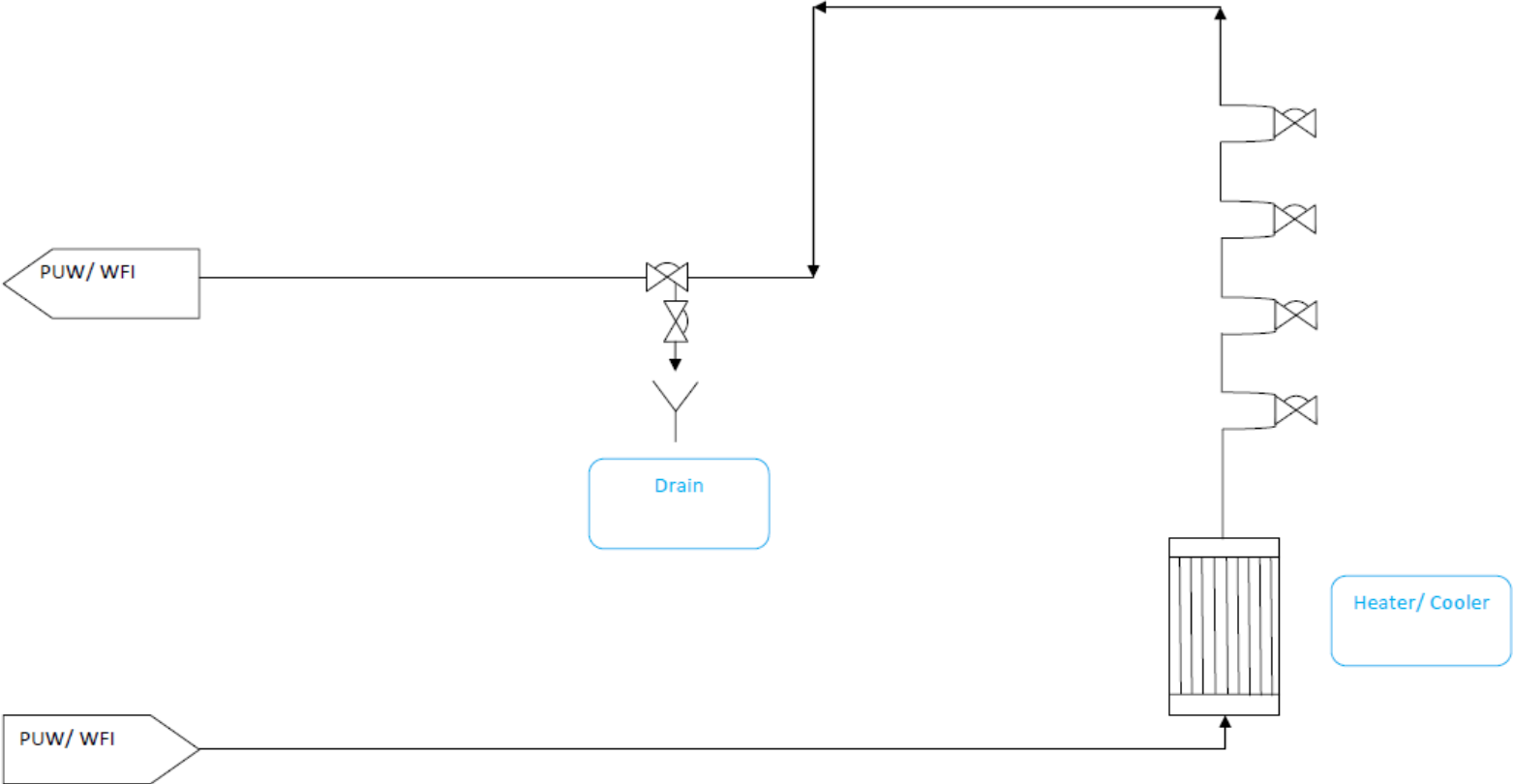

Pumped Cooling Sub-Loop

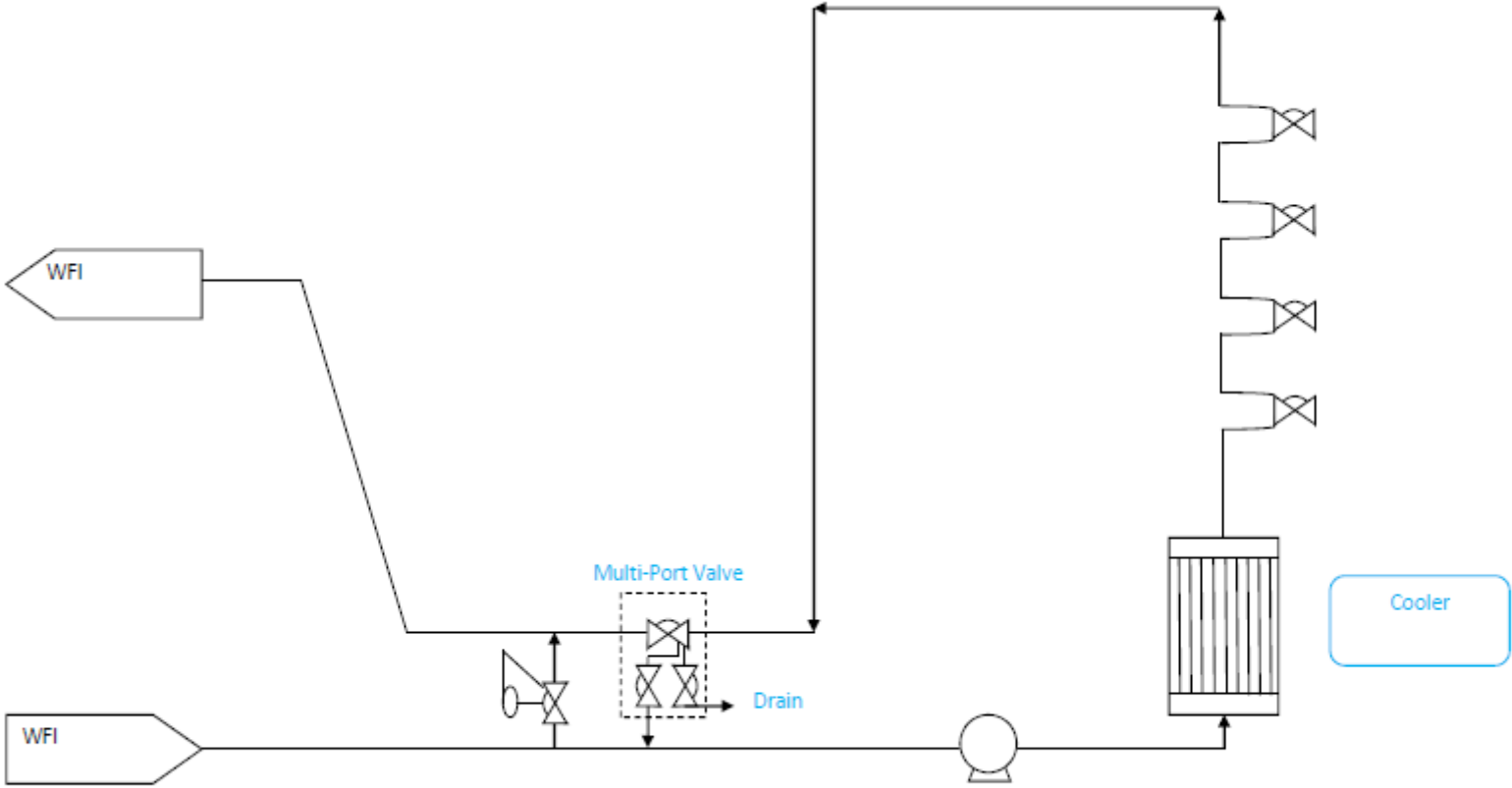

Point of Use Cooling

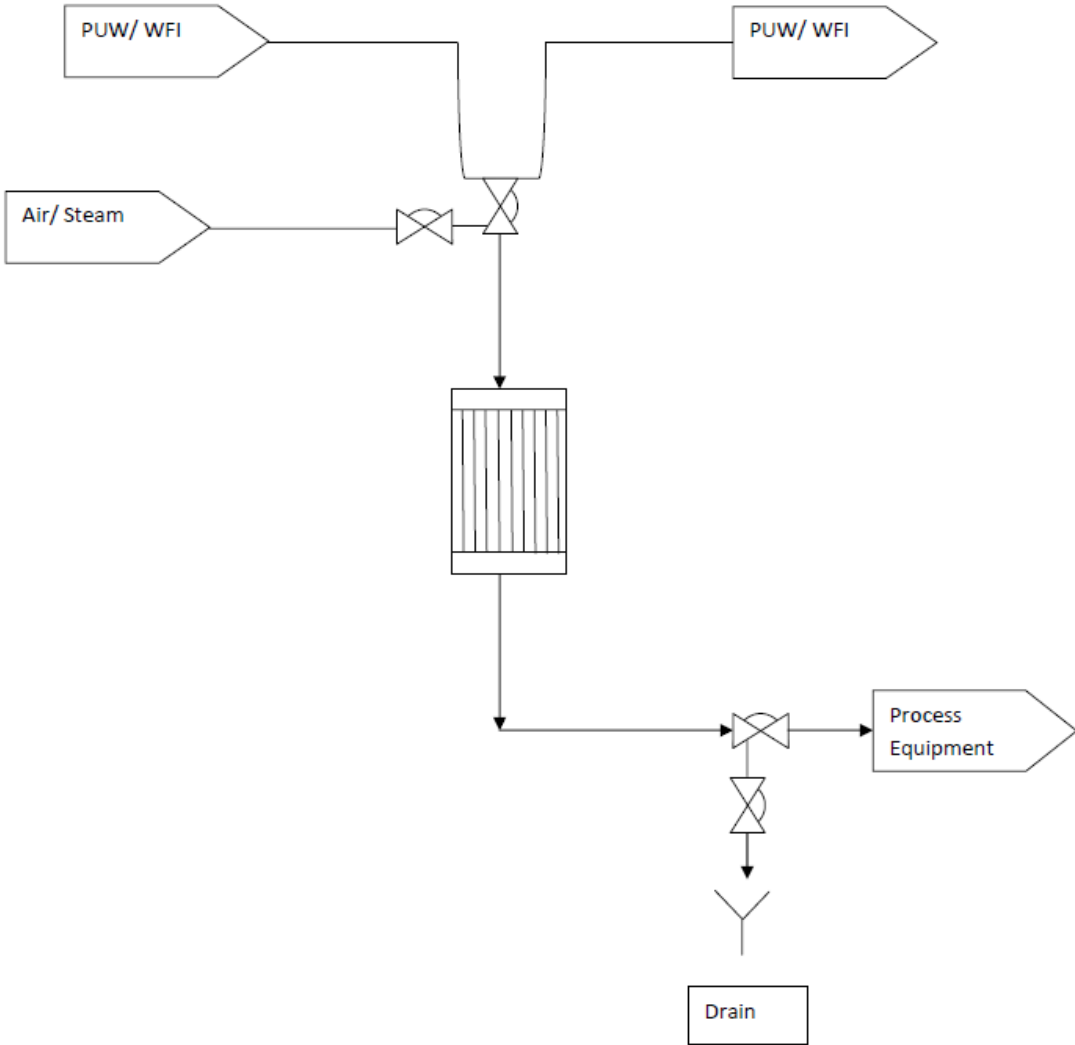

Block and Bleed PUW/ WFI User Point

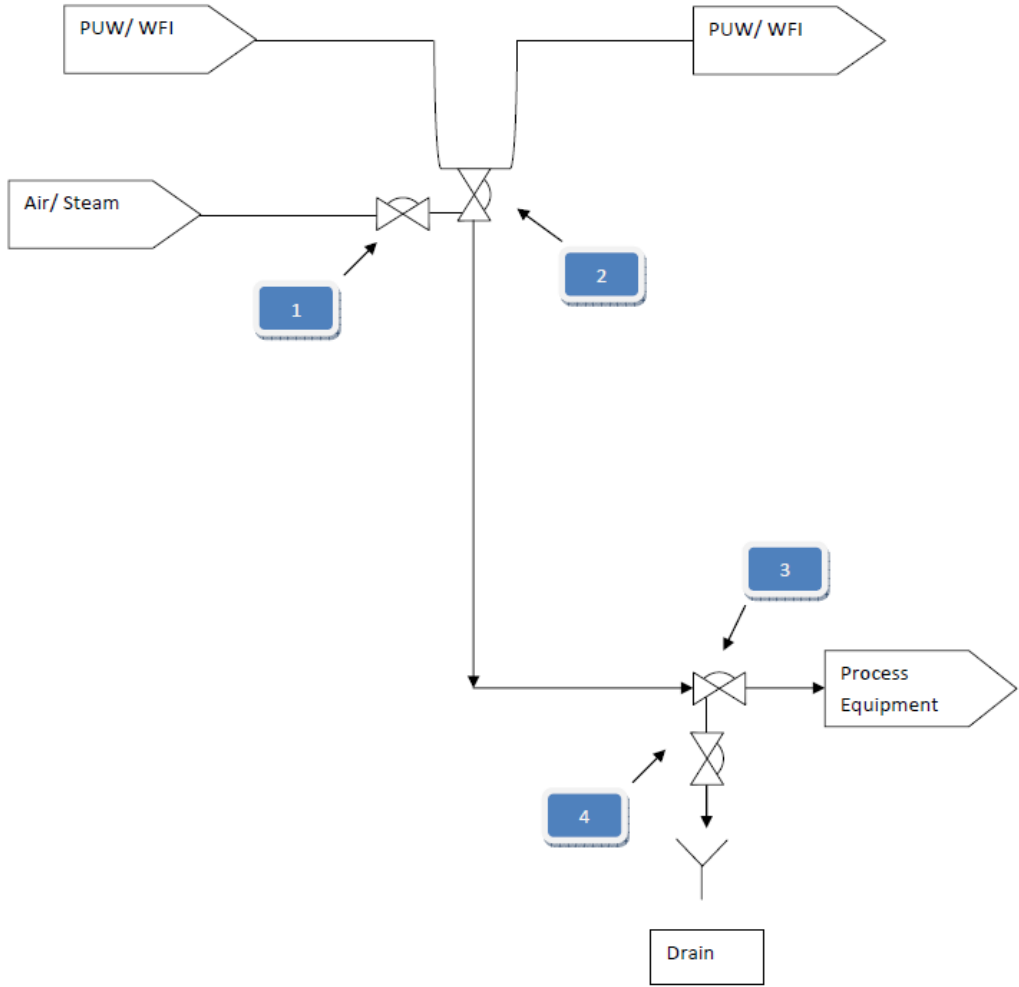

General Design Principles



- Sanitary diaphragm valves used throughout system
- Single mechanical seal centrifugal pumps
- Every line slopes to drain
- Consider designing system for steaming
- Recommend envelope gaskets (PTFE encapsulated EPDM)

Construction



- Very important step which is often overlooked by commissioning team
- Weekly walkdowns
- Inspect welds from day 1
- Review degreasing, pickling and passivation procedures

Vital Construction Activity: Flushing



Install Mesh Gaskets in PUW/ WFI return header throughout commissioning

- A flush exercise which is a few hours long will not remove all particles from the loop
- Many contaminants, such as stainless steel shavings, will not register on a TOC meter or conductivity meter
- Recommended to have mesh gaskets installed for days or weeks: throughout commissioning phase

- Build automation into the design from day one. Crucial to a successful project.
- Develop URS in tandem with P&IDs
- The software cannot be properly developed unless there is a detailed design document (URS or related document). Detail to include:
 - Process Sequences
 - Interlocks
 - Alarms

- Test key design fundamentals:
 - Velocities
 - Slopes
 - Deadlegs
 - Temperatures
 - Water Quality (Sampling)

Commissioning



- Optimise Operation:
 - Efficient and effective sanitisation
 - Operational sequences as per design documents
 - Stress Testing
- Basis of Verification Process
- System Data Gathering

Sampling



- Build Sampling into Design
- Recommended to allow capability to sample at the following points, at a minimum:
 - Generation System Infeed
 - Generation System Outfeed
 - As close as possible to each User Point

Rouging



- Rouging is a film of iron oxides and hydroxides
- Rouging is common in PUW, WFI and Pure Steam systems
- Rouging is acceptable in these systems, however it is recommended to monitor rouging and minimise rouge levels passing into the product

- Class 1: Caused by contamination from external sources, e.g. carbon steel particles getting into a PUW/ WFI/ PS (pure steam) system.

This SHOULD never happen, as all good contractors are very stringent about separation of carbon steel stores from stainless steel stores, using separate tools for carbon steel and stainless steel, etc. If this type of contamination is in the PUW/ WFI/ PS system, I'd recommend shutting it down, draining, passivating, refilling and restarting. An investigation would have to be launched to determine how the contamination entered the system.

Rouging



- Class 2: Rouging in PUW/ WFI systems:

These systems will always rouge, especially if they are > 60 °C. This does not affect the water quality, but it is good practice to design these systems to minimise rouging.

Rouging



- Class 3: Rouging in Pure Steam systems:

These systems will rouge quickly. This does not affect the PS quality, but it's worth considering putting the PS through a steel mesh before it reaches a critical process step. I'd recommend a 1 μm mesh size.

Rouging



- United States Pharmacopoeia 788, Particulate Matter in Injections states maximum particle size 25 μm .
- Rouge particles are typically 1 μm in diameter, but theoretically could clump.
- There is a concern that rouge particles could build up on a surface and release a cloud of fine particles into the PUW/ WFI system if there was a sudden pressure change or mechanical shock.

Rouging



- Parenteral products are normally filtered to 0.2 μm . Excessive rouge levels could inhibit the flow through a filter.
- Not all components of parenteral products are filtered (e.g. suspensions), so the rouge could carry over into the final product.
- What's more, any items which are cleaned with WFI after the final filter could see a build up of rouge, which would carry over into the product.

Rouge – How to Combat



- Risk assessment at start of project reviewing latest information on ferrite levels, velocities, component fabrication methods, etc. Establish a project standard on this basis.
- Avoid the use of nitrogen or other inert atmosphere over the vessel, which will deplete oxygen levels in hot systems

Rouge – How to Combat



- Consider lowering operating temperatures if rouging is found
- Use sacrificial spools to monitor the presence of rouge. Consider inline monitoring.
- Avoid derouging chemicals
- There is no technical data in the industry to support the belief that rouge must be eradicated when found.

Rouging



- Pharmaceutical Water Systems, First Edition, 1997, Theodore H. Meltzer
- FDA Inspection Guide: High Purity Water Systems (7/93)
- ISPE Baseline Guide Volume 4: Water and Steam Systems
- ISPE Good Practice Guide: Commissioning and Qualification of Pharmaceutical Water and Steam Systems

The image features a dark grey background. On the left side, there are several overlapping, curved shapes in shades of green and yellow, resembling a stylized letter 'G' or a similar abstract form. A thin, curved line in a light green color starts from the bottom center and curves upwards and to the right, ending near the top right corner. The word "Questions?" is written in a light green, sans-serif font, positioned in the middle-right area of the image, just below the thin curved line.

Questions?